

PERSIMMON BOULEVARD EAST - PLAT 2

BEING A PLAT OF A PORTION OF SECTIONS 1 AND 12, TOWNSHIP 43 SOUTH, RANGE 40 EAST,
AND SECTION 7, TOWNSHIP 43 SOUTH, RANGE 41 EAST, CITY OF WESTLAKE,
PALM BEACH COUNTY, FLORIDA

17

NORTHWEST CORNER SECTION 1-43-40
FOUND BRASS DISK IN CONCRETE "P.B.C."
N:884612.3299, E:880484.6585
NAD83 (2007 ADJUSTMENT)
CERTIFIED CORNER RECORD #107585

POINT OF COMMENCEMENT
NORTHEAST CORNER OF
SECTION 1, TOWNSHIP 43 S., RANGE 40 E.
SET 3.5" IRON PIPE "PUBLIC LAND SURVEY
CORNER-TALLAHASSEE MERIDIAN"
BRASS DISK "10' EAST" SET IN CONCRETE
FOUND 10' EAST ON SECTION 14E
N: 884626.7147
E: 886137.1629
NAD83 (2007 ADJUSTMENT)
CERTIFIED CORNER RECORD #107597

SOUTH LINE OF SECTION 31,
TOWNSHIP 42 S., RANGE 41 E.

BASIS OF BEARING
NORTH BOUNDARY
OF SECTION 6,
TOWNSHIP 43 S., RANGE 41 E.
S.89°48'53"E, 5270.23'
(MEASURED)
S.89°48'52"E, 5270.39'
(COUNTY)

NORTHEAST CORNER
SECTION 6-43-41
FOUND BRASS DISK IN
CONCRETE "P.B.C."
N:884609.6818 E:891407.3638
NAD83 (2007 ADJUSTMENT)
CERTIFIED CORNER
RECORD #107591

SHEET MAP
(NOT TO SCALE)

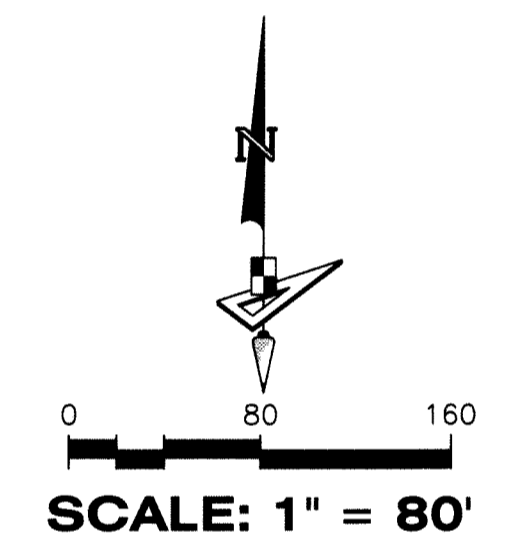
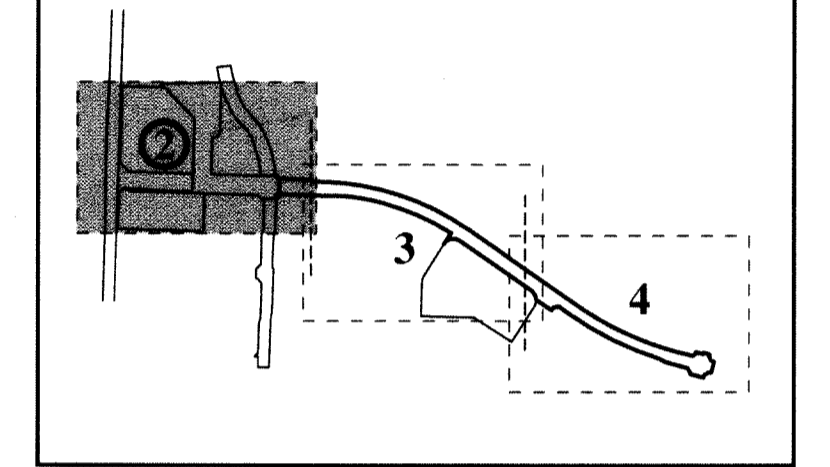

LEGEND

- P.O.B. ----- POINT OF BEGINNING
- P.B. ----- PLAT BOOK
- D.B. ----- DEED BOOK
- PG./PG(s) ----- PAGE(s)
- O.S.T. ----- OPEN SPACE TRACT
- P.B.C. ----- PALM BEACH COUNTY
- U.E. ----- UTILITY EASEMENT
- R ----- RADIUS
- L ----- ARCH LENGTH
- D ----- DELTA ANGLE
- CB ----- CHORD BEARING
- C ----- CHORD
- 12-43-40 ----- SECTION-TOWNSHIP-RANGE
- ----- FOUND PERMANENT REFERENCE MONUMENT
- ----- SET PERMANENT REFERENCE MONUMENT
- ----- PERMANENT CONTROL POINT
- ⊕ ----- CENTERLINE
- R/W ----- RIGHT-OF-WAY
- O.R./O.R.B. ----- OFFICIAL RECORDS BOOK

BASIS OF BEARINGS

BEARINGS SHOWN HEREON ARE BASED ON THE NORTH BOUNDARY OF SECTION 6, TOWNSHIP 43 SOUTH, RANGE 41 EAST, HAVING A GRID BEARING OF S.89°48'53"E. (MEASURED). BEARINGS SHOWN HEREON, REFER TO THE STATE PLANE COORDINATE SYSTEM, NORTH AMERICA DATUM OF 1983 (NAD 83 - 07) FOR THE EAST ZONE OF FLORIDA. SAID BASIS OF BEARING IS THE SAME IN THE NORTH AMERICAN DATUM OF 1983 (NAD 83 - 90).

COORDINATES SHOWN HEREON ARE FLORIDA STATE PLANE GRID DATUM = NAD83 2007 ADJUSTMENT ZONE = FLORIDA EAST LINEAR UNITS = US SURVEY FEET COORDINATE SYSTEM = 1983 STATE PLANE PROJECTION = TRANSVERSE MERCATOR ALL DISTANCES ARE GROUND SCALE FACTOR: 1.0000 GROUND DISTANCE X SCALE FACTOR = GRID DISTANCE PLAT BEARING = GRID BEARING NO ROTATION ALL TIES TO SECTION CORNERS AND QUARTER CORNERS ARE GENERATED FROM MEASURED VALUES

NOTICE: THIS PLAT, AS RECORDED IN ITS GRAPHIC FORM, IS THE OFFICIAL DEPICTION OF THE SUBDIVIDED LANDS DESCRIBED HEREIN AND WILL IN NO CIRCUMSTANCES BE SUPPLANTED IN AUTHORITY BY ANY OTHER GRAPHIC OR DIGITAL FORM OF THE PLAT. THERE MAY BE ADDITIONAL RESTRICTIONS THAT ARE NOT RECORDED ON THIS PLAT THAT MAY BE FOUND IN THE PUBLIC RECORDS OF THIS COUNTY.

